



Contents List:

(1) Fully machined 6061-T6 aluminum distributor with vacuum advance

(1) Pre-installed rotor

(1) Pre-installed cap

(1) Plug wire retainer with two self tapping screws

(1) Gasket

(1) Lock out kit for vacuum advance

(1) Three-pin wire harness

(2) O-rings, for use with modified engine block

(4) Advance stop bushings, blue pre-installed

Red = 28 crankshaft degrees Silver = 25 crankshaft degrees

Blue = 21 crank shaft degrees Black = 18 crankshaft degrees

(3 pr) Advance springs, black pre-installed

1 pair blue – normal rate of advance

1 pair silver – faster rate of advance

1 pair black – slower rate of advance

(1 pr) Replacement allen-head screws

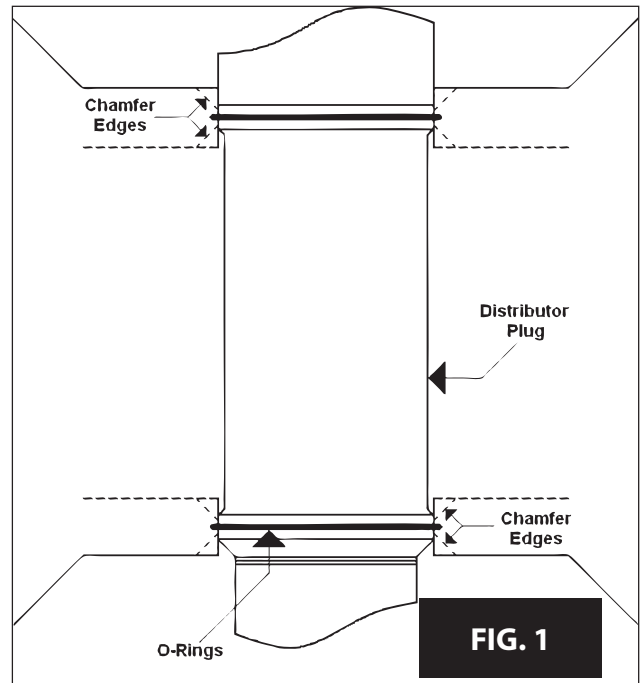

Distributor Removal/Installation

1. Remove the existing distributor cap, but do not disconnect any spark plug wires.
2. Use a remote start switch or have a helper crank engine until the rotor is pointed at the #1 cylinder.
3. Disconnect the battery cables, remove the NEGATIVE (-) cable first.
4. Reinstall the distributor cap briefly to check that the rotor and the #1 spark plug wire are in line. Once noted, remove cap and lay to the side. If necessary, mark spark plug wires and remove them from the distributor cap.
5. Disconnect all other wires to distributor, noting where they were attached.
6. Loosen the distributor hold down clamp and rotate the clamp to the side or remove. Lift distributor straight up to remove from the engine. (The spiral cut gear will cause the rotor to rotate as the distributor is pulled out of the engine. Be sure to compensate for the spiral gear shape when installing the new distributor.)
7. Remove old gasket and clean surface to prepare for new gasket.
8. Install O-rings if engine block has been modified. See figure 1.
9. Install the gasket between distributor and intake manifold.
10. Apply a liberal amount of zinc or moly grease to the distributor gear to ensure proper gear break-in. (Grease sold separately. If the distributor does not drop into place and fully seat against the intake manifold, remove the distributor and, using a long, standard screwdriver, rotate the oil pump shaft with a long screwdriver until the shaft lines up with the distributor drive. Make sure distributor is fully seated after this adjustment (there should not be any gap between distributor housing, gasket and intake manifold).
11. Reinstall or reposition the distributor hold down clamp, and then tighten until ready to set ignition timing.
12. Starting with the spark plug wire noted in step 4, position the cap on the distributor and install this spark plug wire on the terminal that the distributor rotor is aligned to.
13. Attach the distributor cap.

Allstar Performance 8300 Lane Drive, Watervliet MI 49098
Phone: (269) 463-8000 Fax: (800) 772-2618 www.allstarperformance.com



14. Secure remaining spark plug wires one by one to ensure accuracy using original cap and marks from step 4 as a reference.
15. Reconnect battery cables. Be sure to hook up the NEGATIVE (-) cable last.
16. Set ignition timing according to manufacturers or engine builder's specifications.

Distributor Final Connections

Included with distributor is a harness with a weather tight connector which allows easy connection to most vehicles with or without an ignition control box. See Figure 2.

Centrifugal Advance Curve

A combination of springs, weights, advance stop bushing, and an advance cam make up the working parts of the centrifugal advance. By changing springs and the advance stop bushing, this distributor will operate in a wide range of applications.

Advance Curve

The function of advance curve is to match ignition timing to the burning rate of fuel and RPM of engine. Timing may need to be changed if the burning rate of fuel or engine RPM are altered.

When selecting an advance curve, use as much initial advance as possible without causing excessive starter load or engine kick back. Start the centrifugal advance just above idle RPM. The starting point of centrifugal advance curve is controlled by the installed length and tension of the spring. Advance spring stiffness controls the rate of the centrifugal advance slope. A lighter spring will provide a faster advance curve. Advance bushing size controls the amount of advance. A smaller bushing will produce a smaller amount of advance. The following factors will affect engine timing.

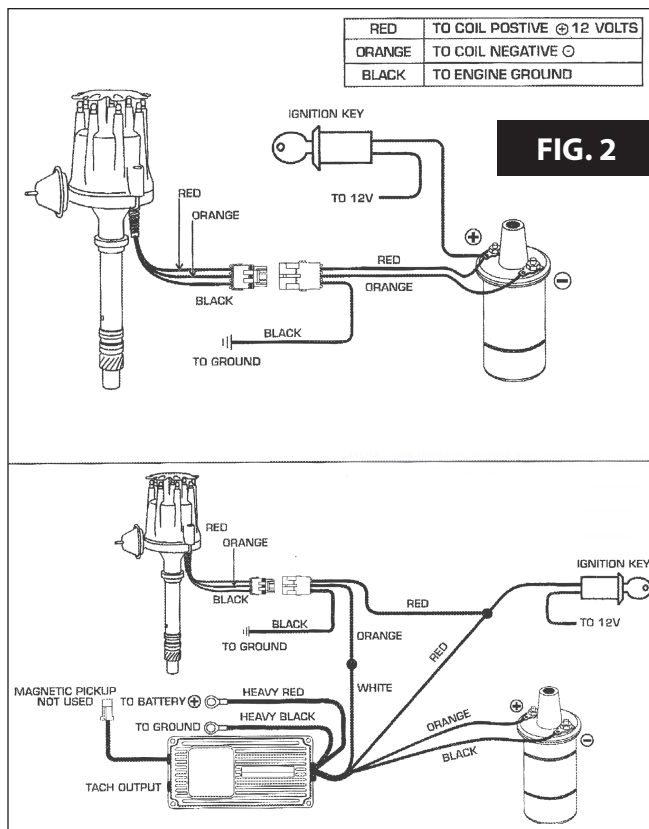

Factor	Delay Timing	Advance Timing
Air & Fuel Mixture	Lean	Rich
Combustion Chamber Shape	Compact	Open
Combustion Turbulence	High	Low
Cylinder Pressure	High	Low
Octane Of Fuel	Low	High
Ignition Energy	High	Low
Load	Heavy	Light
RPM	Low	High
Spark Plug Location	Centered	Offset
Temperature	Hot	Cool
Vacuum	Low	High

Allstar Performance 8300 Lane Drive, Watervliet MI 49098
Phone: (269) 463-8000 Fax: (800) 772-2618 www.allstarperformance.com



Changing Advance Springs

Remove distributor cap and rotor. Remove springs from spring posts using a pair of needle nose pliers. Install new springs with needle nose pliers, reattach rotor, reattach cap. **See Figure 3.**

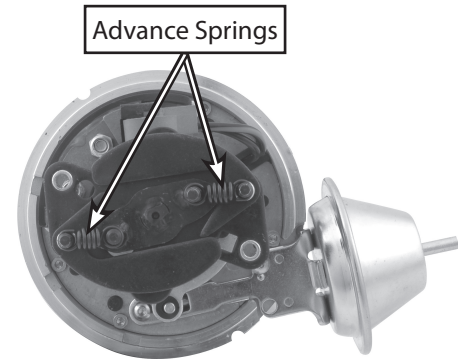

FIG. 3

Changing Advance Stop Bushing

Remove distributor cap and rotor. Remove locknut and washer on bottom of advance assembly. Simply remove existing bushing and replace with new bushing. Install washer, tighten locknut, reattach rotor, reattach cap. **See Figure 4.**

Locking Centrifugal Advance

Remove advance springs, weights, and advance stop bushing - a small locknut with nylon insert and washer holds the advance stop bushing in place. Next remove roll-pin from the drive gear and remove the gear from shaft. While sliding the shaft out of the housing, approximately 2 ½ inches, rotate the shaft 180 degrees and insert the advance stop bushing pin into the hole of advance plate. Reattach the washer and locknut to the advance stop bushing pin. Reinstall the drive gear and roll pin. **See Figure 4.**

FIG. 4

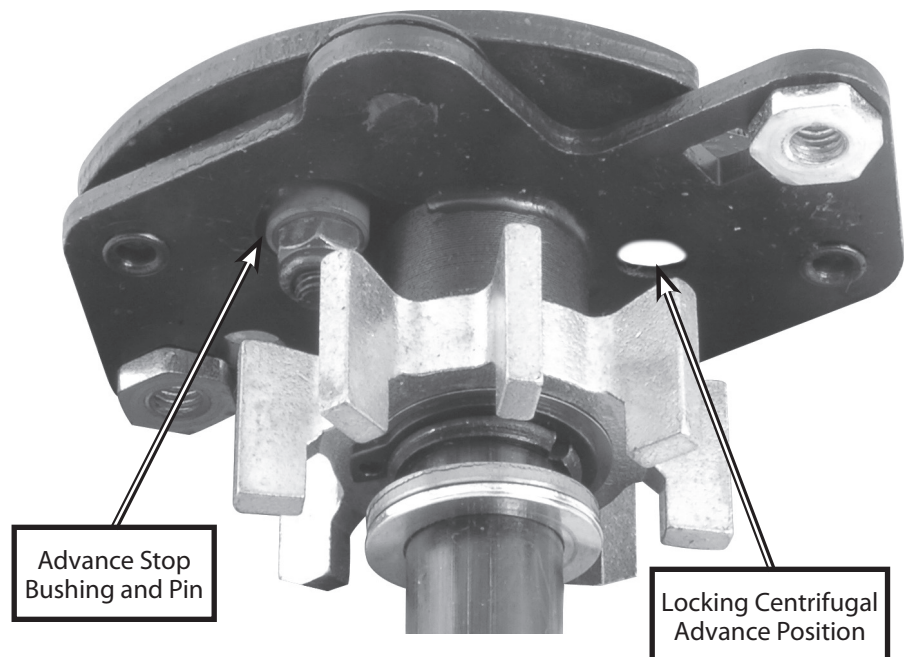

Allstar Performance 8300 Lane Drive, Watervliet MI 49098
Phone: (269) 463-8000 Fax: (800) 772-2618 www.allstarperformance.com



Locking Out Vacuum Advance

1. If you have decided to the vacuum advance, this modification is most easily accomplished before distributor installation.
2. Remove roll-pin from the drive gear and remove the gear and thrust washer from shaft.
3. Remove shaft from housing.
4. First remove the two Allen head screws that secure the advance canister to the distributor. See Figure 5.
5. Using a pair of snap ring pliers, remove the snap ring that holds the magnetic pickup plate in place. See Figure 5.
6. Lift up on the magnetic pickup to complete vacuum canister removal.
7. Next secure the lock out plate onto the distributor housing using the previously removed Allen head screws. At this point, only slightly tighten.
8. Install one of the supplied machine screws with washer though the lockout and tighten.
9. If the pickup plate is installed incorrectly, be cautioned that the reluctor paddles could come into contact with the pickup. Be sure to install the pickup plate parallel with the distributor housing and always check for proper clearance by inserting shaft assembly and rotating distributor shaft. If contact between the reluctor paddles and pickup is observed, use one of the included shims between the lockout plate and distributor housing to compensate. If no shims are needed between the lockout plate and distributor housing, use one beneath the washer of machine screw which holds down the lockout plate.
10. Once you've confirmed that the reluctor paddles do not come into contact with the pickup, fully tighten the Allen head screws, remove shaft assembly and reinstall the snap ring.
11. Install shaft assembly back into housing, install thrust washer, gear and roll pin.

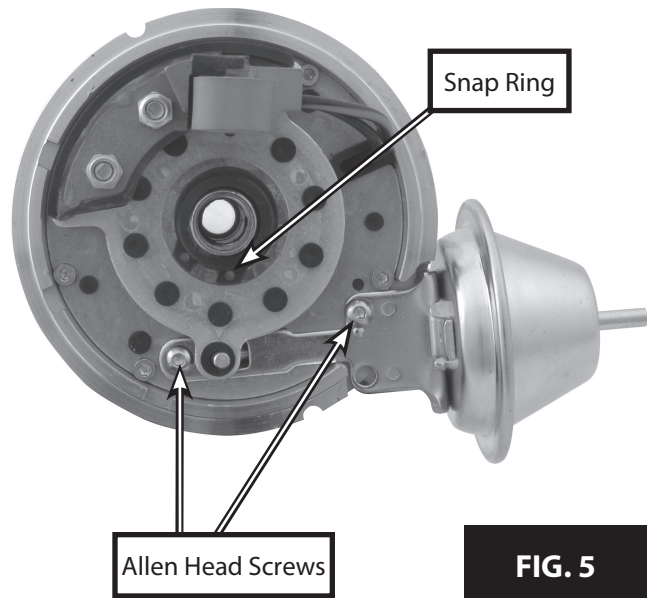

FIG. 5

Note: Be sure to recheck your timing and plug any existing vacuum ports.

Break-In Period Required

- Prior to completion of the installation, the distributor gear should have received a coating of zinc or moly based grease (grease sold separately). It is the responsibility of the installer to apply this grease.
- Do not use synthetic oil during break-in period. Once break-in period is complete, any suitable oil may be used.
- On modified engines with oil pressure above 70 psi (cold), the gear should be broken-in with racing grade mineral oil.
- Monitor gear wear after several hours of break-in. Check the gear for proper mesh, alignment, and wear.

Limited Warranty

Manufacturer's obligation for warranty returns shall be limited to repairing, replacing, or crediting as its option, any parts found to be defective. Manufacturer will not be liable for charges and/or other expenses incurred, nor shall it be liable for damages or injury to persons or property resulting from the misuse or improper installation of any part subject to this warranty. The warranty contained herein is expressly in lieu of any and all other warranties, including any implied warranty of merchantability or fitness for any particular purpose.

Allstar Performance 8300 Lane Drive, Watervliet MI 49098
Phone: (269) 463-8000 Fax: (800) 772-2618 www.allstarperformance.com