



Electric Line Lock Kit

INSTALLATION INSTRUCTIONS

IMPORTANT INFORMATION:

Carefully read instructions before installing kit. If you are not qualified or experienced in this type of installation, it is highly recommended that you enlist the services of a qualified automotive mechanic. These instructions contain warnings that must be observed; otherwise the vehicle could be rendered unsafe, resulting in possible serious injury to car and driver.

The solenoid valve is designed for use in front brake systems for racing, but can be used in rear brake systems for momentary (maximum of 60 seconds) hill holding. In these conditions, the solenoid valve should not interfere with normal brake operation.

All fittings and brake lines are sold separately. Only SAE approved seamless steel brake lines with double flared ends should be used. Do not use copper tubing. Brake lines are available in a variety of lengths and come pre-assembled with tube nuts.

Use thread sealant tape on threaded fittings. If you use thread sealer, take extra care not to get any inside the lines; otherwise contamination can and will occur.

To be street legal, the rear brake lights must operate when the brake system is under pressure. Therefore, a pressure-operated switch must be installed if the brake lock defeats the purpose/function of the stock rear brake light switch. See step #7 of Electrical Installation before proceeding. (Not required for off-road and drag racing.)

SAFETY PRECAUTIONS:

This kit is designed primarily for high performance race cars to momentarily (maximum of 60 seconds) keep the front brakes engaged while staging for a drag race, it will not safely function as a long-term brake holding device. Kit should only be used on cars and light duty (¾ ton or less rated) trucks using a standard hydraulic braking system that is in a safe, operable condition. It should never be used as a temporary brake holding device in place of a parking brake or as a replacement for a driver depressing the brake pedal. This kit is not recommended for vehicles with anti-lock or split diagonal brake systems. It can, however, be made to work in racing conditions only.

The solenoid valve must be securely mounted to prevent flexing of brake lines. Unsecured mounting can cause premature failure. The solenoid must be mounted away from areas like suspension components, steering components, headers, and exhaust pipes. An area such as the firewall is suggested, and a line-fitting wrench is always recommended on all line fittings while installing the brake lines.

When working on brake system it is always important not to allow contaminants (dirt or foreign matter) to get into the lines or fluid. This may cause improper operation and failure.

Use a tube bender to avoid kinking or crushing if bending lines is necessary: there must be no leakage!

INSTALLATION INSTRUCTIONS:

This kit includes a stainless steel, nickel-plated, corrosion-resistant valve assembly for superior reliability and extended durability.

1. Install a 1/8" N.P.T. male fitting (non-included) in the valve inlet port (top port closest to heat sinks, FIGURE 1) and in selected outlet ports of the solenoid valve. Elbow fittings may be used where necessary. Non-used outlet ports must be sealed with (included) 1/8" N.P.T. plugs. **CAUTION:** Do not clamp kit in vise or damage will occur to motor and magnet. Do not over-tighten fittings.
2. Mount solenoid valve close to the brake lines (away from headers, exhaust pipes, steering and suspension components), which you will be using for connecting the brake lock system. Valve may be mounted in any position (vertical-horizontal, etc.). Using a 3/16" or #13 drill bit, drill holes for mounting and fasten with supplied ¼" sheet metal screws. Secure the black ground wire under one of the 1/4" sheet metal screws. Use a solderless/crimp connector terminal on the end of this wire. If this is not a sufficient electrical ground, run an auxiliary wire to the engine block or negative (-) terminal of the battery.
3. Install new steel brake lines if necessary.
4. Additional brake lines may be connected to existing lines by using appropriate size inverted flare union fittings. Any one of the outlet ports on the valve body can be used for installing a pressure gauge if so desired. It is recommended that this be done at this time.
5. Be sure to use a top quality, factory-recommended, heavy-duty brake fluid that meets D.O.T.3 or D.O.T.4 specifications.

Allstar Performance 8300 Lane Dr., Watervliet, MI 49098

Phone: (269) 463-8000 Fax: (800) 772-2618 www.allstarperformance.com



ELECTRICAL INSTALLATION:

Kit is designed for 8 to 16 Volt DC operation only.

To assure good electrical connections use 18-gauge standard insulated automotive wire or equivalent and solder all splices together. Always wrap each splice/connection with quality grade electrical tape or heat shrink sleeve.

1. Disconnect negative (-) cable from battery.
2. Mount lock activation switch in a convenient and easy to reach position.
3. Mount indicator lamp in convenient location under dash, or drill an 11/16" diameter hole in instrument panel, if so desired, for in-dash mounting. Use caution when drilling. Check for obstructions behind instrument panel before drilling any holes. Mount indicator lamp and splice lamp wire to end of switch wire. Be sure that indicator lamp bracket is grounded.
4. A three way splice must now be made using the wire from the lamp, one of the wires from the switch (either will work), and the red wire from the solenoid valve.
5. Using a length of 18-gauge wire, splice one end to the second wire of the switch and connect the other end to a switched positive terminal so that the brake lock is only operable with the ignition turned on. A Snap-Lok fuse holder with 4-amp fuse is provided and should be incorporated into this wire. The fuse will protect your electrical system in the event of a short circuit.
6. Reconnect battery and turn ignition switch on. Depress the switch several times and check fuse. If fuse is burned, check all electrical connections for a short.
7. Turn ignition switch on. Apply the brakes and depress the switch button. While still holding the switch, release the brake pedal. Your brake lights must operate when the hydraulic system is under pressure and the solenoid valve is engaged. If not, connect a hydraulic brake light switch to one of the outlet ports of the solenoid valve. Electrical hook-up should be parallel to existing pedal brake switch wiring.

After installation, bleed all air out of the system. Follow vehicle manufacturer's brake bleeding procedures. Bleed air at wheel cylinders or calipers starting with wheel furthest from master cylinder and ending with closest. Be sure to check all connections for leakage under pressure.

CAUTION: Before driving vehicle, completely check the brake system for proper operation. Check all connections under pressure for leaks and be sure that you have a good, solid brake pedal. Test the system several times to be sure that it operates correctly. Be sure that the proper two wheels have the brakes engaged when the brake lock is actuated and that all four wheels are free when the switch is released.

OPERATING INSTRUCTIONS:

With the ignition in the "on" position, fully depress brake pedal to firmly engage brakes, and then depress the switch button. The indicator lamp should light up when switch button is depressed, indicating that the solenoid valve is actuated. The operation of the brake lock will now allow you to release the brake pedal and maintain an engaged front brake system for racing applications. This will allow you to preload the drive train without roll out.

To disengage the line lock, release the switch button. **WARNING:** Never depress switch button while applying brakes and the vehicle is in motion.

Allstar Performance 8300 Lane Dr., Watervliet, MI 49098
Phone: (269) 463-8000 Fax: (800) 772-2618 www.allstarperformance.com



System 1

Dual Master Cylinder

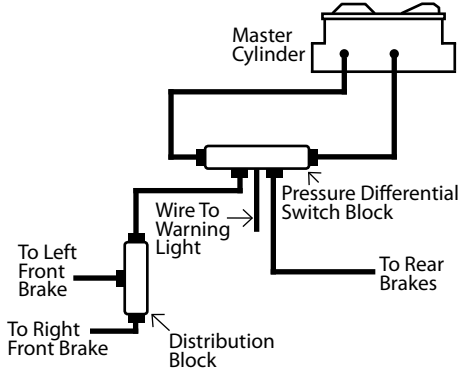

Roll Control Installed Front Brakes Only

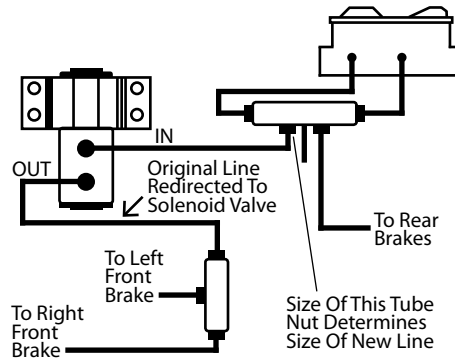

Roll Control Installed Rear Brakes Only

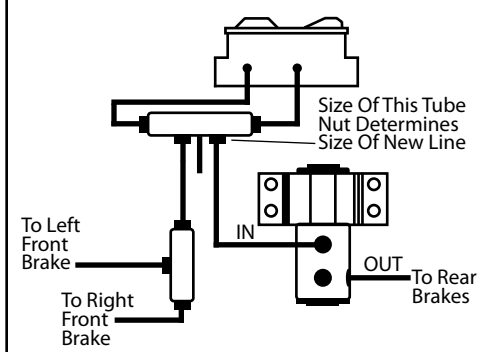

System 2

Dual Master Cylinder

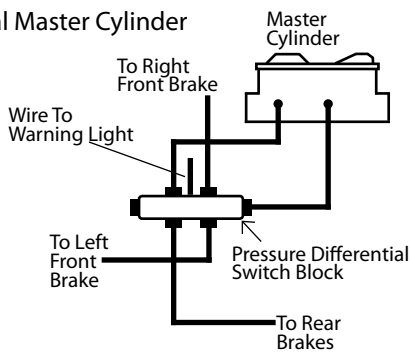

Roll Control Installed Front Brakes Only

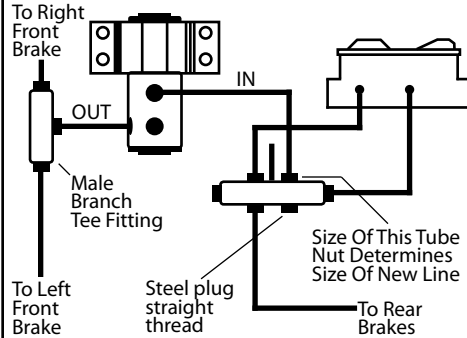

Roll Control Installed Rear Brakes Only

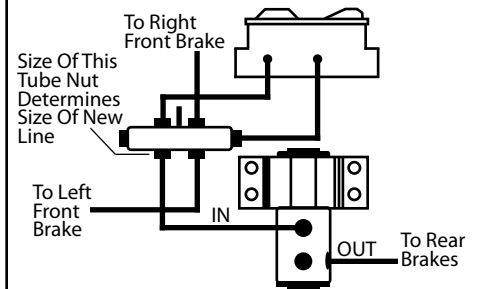

System 3

Dual Master Cylinder

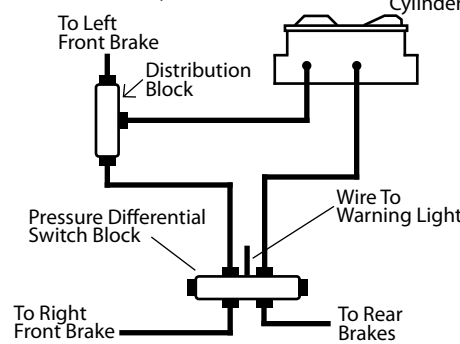

Roll Control Installed Front Brakes Only

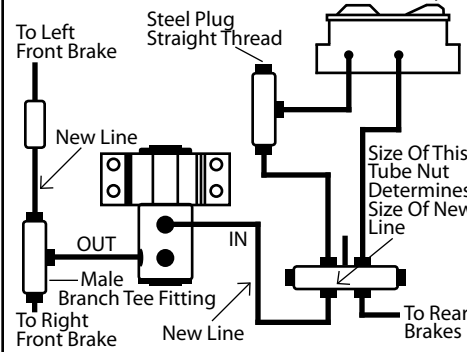

Roll Control Installed Rear Brakes Only

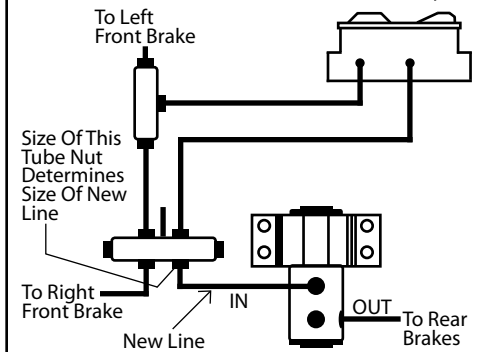

Allstar Performance 8300 Lane Dr., Watervliet, MI 49098
Phone: (269) 463-8000 Fax: (800) 772-2618 www.allstarperformance.com



Line From Master Cylinder
Inlet (x1)

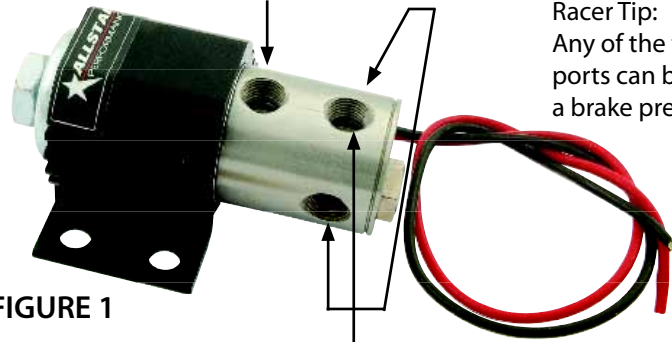

Racer Tip:
Any of the three outlet
ports can be used with
a brake pressure gauge.

FIGURE 1

Outlet Ports (x3)

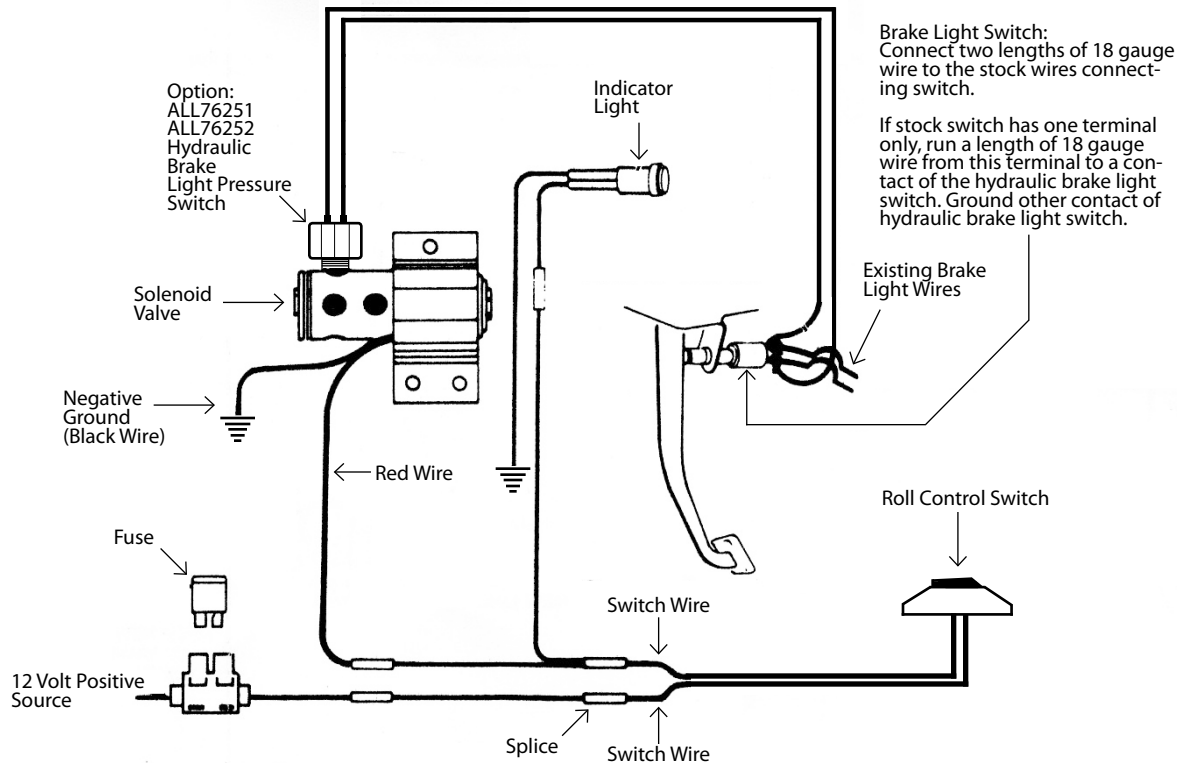

Optional Components

Part Number	Description	Qty. Per Package
ALL50120	1/8" NPT To 3/16" Inverted Flare	4
ALL50121	1/8" NPT To 1/4" Line	4
ALL50130	3/16" Inverted Flare Union	4
ALL50182	1/8" NPT Brass Plug	4
ALL50183	3/16" Inverted Flare Steel Plug	4
ALL76251	1/8" NPT Brake Light Switch - Pressure (Male Bullet Terminals)	1
ALL76252	1/8" NPT Brake Light Switch - Pressure (6-32 Screw Terminals)	1

Allstar Performance 8300 Lane Dr., Watervliet, MI 49098

Phone: (269) 463-8000 Fax: (800) 772-2618 www.allstarperformance.com